

EN Quick guide iROB[®] 420



A	Ethernet connection	
B	Power connection	
C	Ground cable connection	
D	Cable assembly connection	
E	Wire feeder connection	
F	Switch voltage	

This Quick guide is part of the technical documentation and is only valid in connection with the operating instructions for the system components. Read and observe all documentation for the system components.

Installation

- ① Switch the main switch to <Off>.

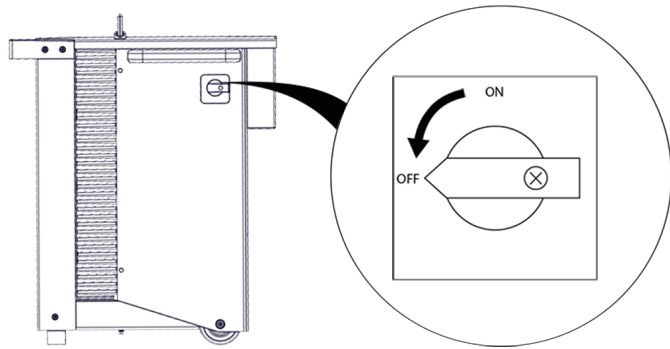

- ② Select the voltage. Switch to <400> or <480>.

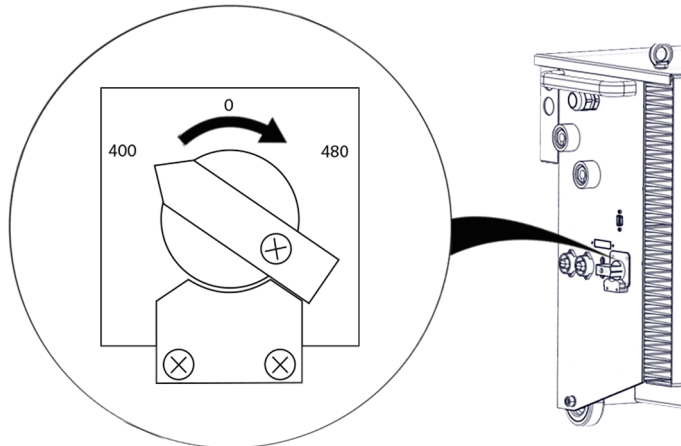

- ③ Connect the ground cable to the welding power source and the welding table.

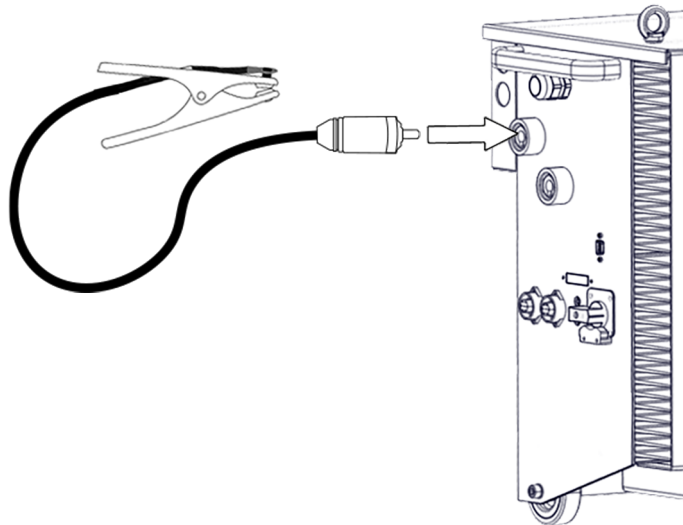

- ④ Connect the cable assembly to the welding power source and the wire feeder and the gas supply.

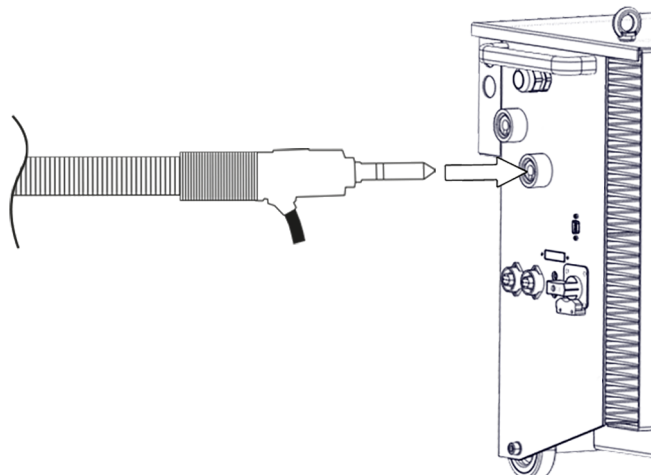

- ⑤ Connect the connecting cable from the wire feeder to the welding power source and the wire feeder.

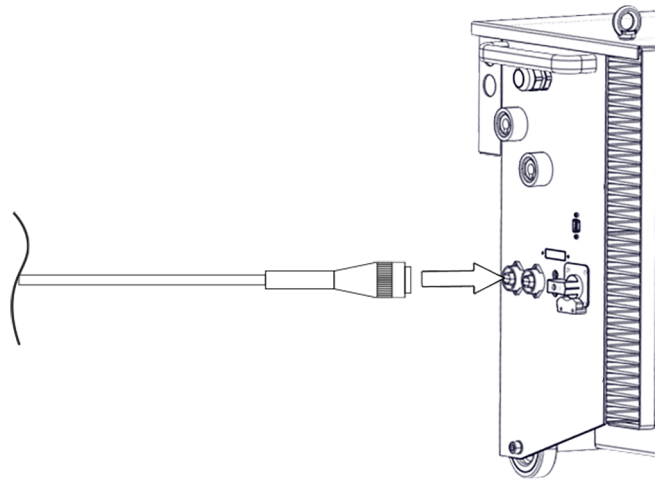

- ⑥ Connect the Ethernet cable to the power source and the robot controller.

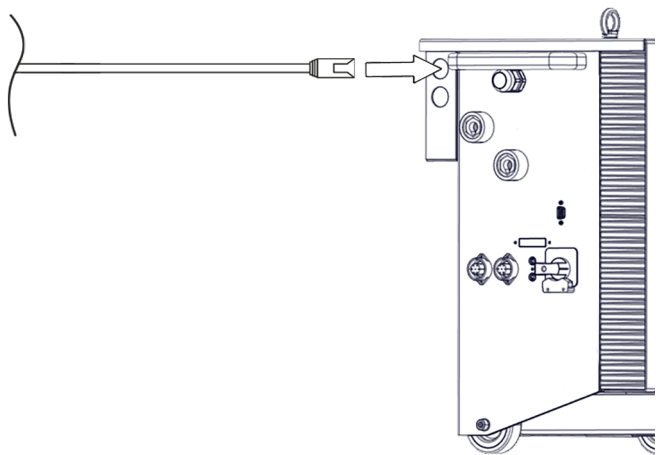

- ⑦ Connect the welding power source to the power supply.

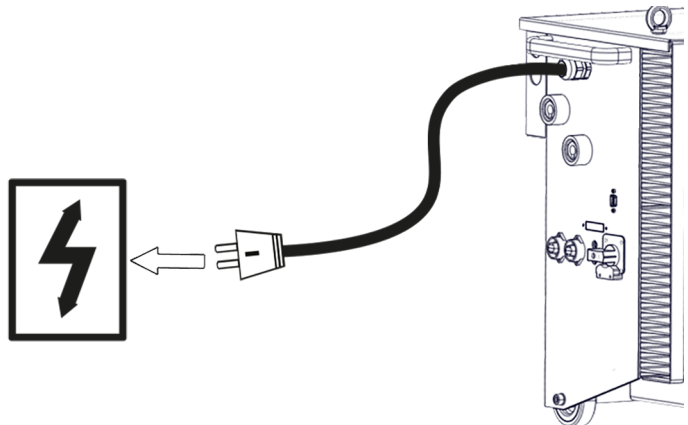

- On the teach pendant, start the software and log in.
- ⑧ Select <Welding Machinery> in the settings menu and select <SKS power source>.

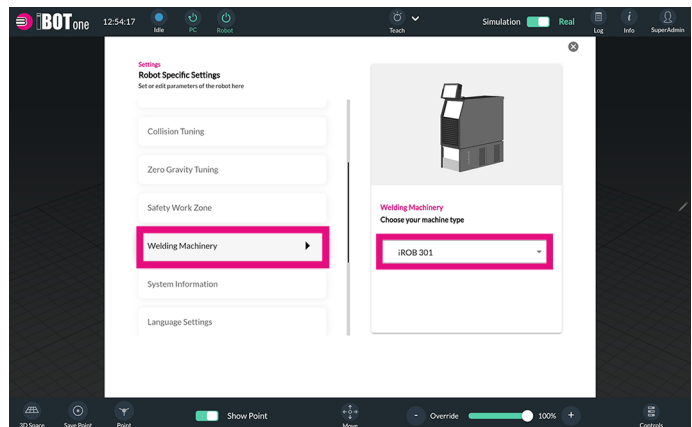

System overview

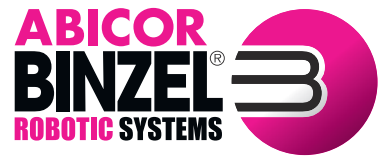
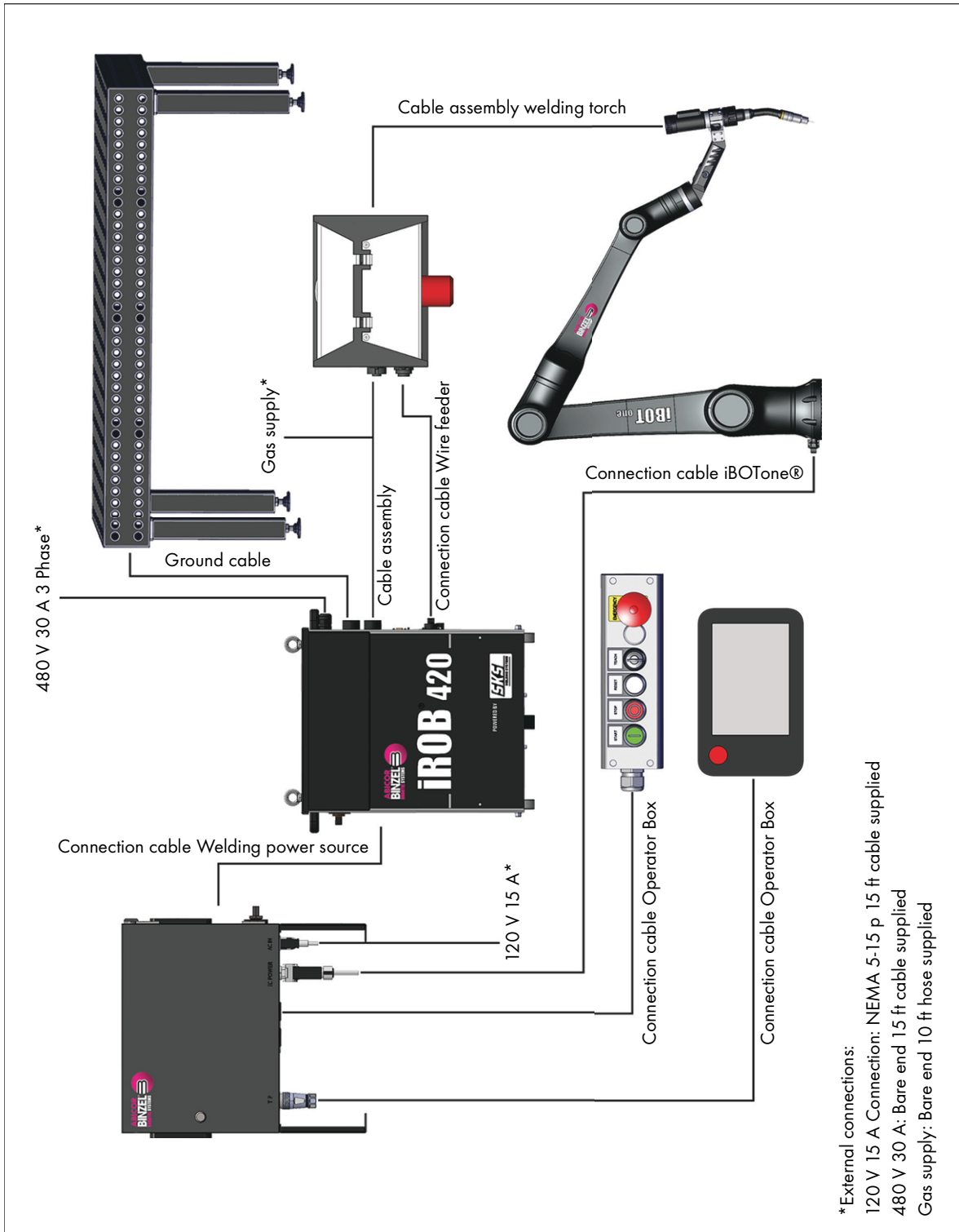

ABICOR BINZEL USA
 650 Medimune Court
 P: 301-846-4196
 TF: 800-5424867
 marketing@binzel-abicor.com
www.binzel-abicor.com