

TECHNOLOGY FOR THE WELDER'S WORLD.



**Powerful, sturdy
and flexible.
ABIMIG® W T.**

BASIC & COMBI



www.binzel-abicor.com

MIG/MAG Welding Torches "ABIMIG® W T"

Liquid cooled • rating 450 A up to 600 A

Welding torches in the ABIMIG® W T series convince through higher load limits than traditional torches of the same size, because the cooling concept that was redesigned by ABICOR BINZEL protects wear parts even better against overheating.

A spatter protector integrated in the gas nozzles makes them particularly resistant. In addition, the torch necks and the gas nozzle are nickel-plated, in order to reduce spatter adhesions.

Thanks to the rotatable and exchangeable torch necks welders can adjust the ABIMIG® W T torch exactly to their needs.

- Long-life screw-in gas nozzles with integrated, exchangeable spatter protection
- Quick change, 360° positionable torch necks – increase working comfort and reduce servicing costs
- Extended and short triggers available – for best handling
- Tried-and-tested ergonomic grip – easy to hold in all positions



ABIMIG® W T 440

Technical data (EN 60 974-7):

Rating: 500 A CO₂
 450 A Mixed Gases
 350 A Pulse
 M21 (DIN EN 439)

Duty cycle: 100%

Wire size: 0.8–1.6 mm

ABIMIG® W T 540

Technical data (EN 60 974-7):

Rating: 600 A CO₂
 550 A Mixed Gases
 400 A Pulse
 M21 (DIN EN 439)

Duty cycle: 100%

Wire size: 1.0–1.6 mm

The "COMBI" modular system offers the possibility to adapt various pre-defined necks with the base torch.

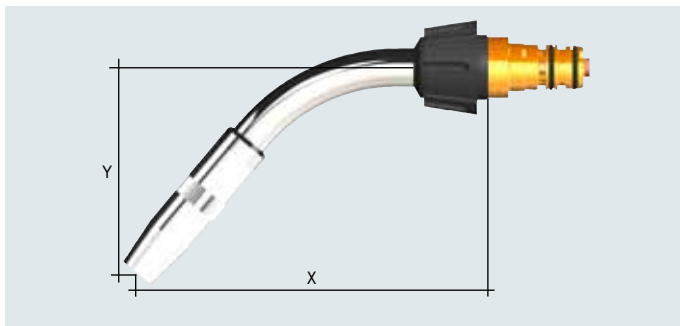

removable and rotateable torch necks.



Standard and extended trigger handle options.

Note for liquid cooled torches:

To protect cable assembly components from excessive heat build up we recommend a post welding cooling cycle of at least four minutes.

Ordering Instructions for Complete WT

WT5		15	-	5	T	45	-	E	T	S
Torch Model/ Amperage		Cable Length		Neck	Nozzles	Wire Size		Back End	Handle	Trigger
Torch Model				Neck						Trigger
WT - Removable neck Hand-held water-cooled MIG Gun				5 - 50 Degree						S - Standard Trigger E - Extended Trigger
Amperage				Nozzle						Handle Options
4 - 450 Amp mixed gas (WT 440) 5 - 550 Amp mixed gas (WT 540)				T - Thread-on						T - ABIMIG WT
Cable Length				Wire Size						Back End
10 feet 12 feet 15 feet				35 - .035" 45 - .045" 52 - .052" 62 - .062"						E - Euro L - Lincoln (Ext. gas) N - Lincoln 10 (Int. gas) T - Tweco 4 (Int. gas) M - Miller (Int. gas) V - Lincoln Power MIG (Int. gas)

Wear parts

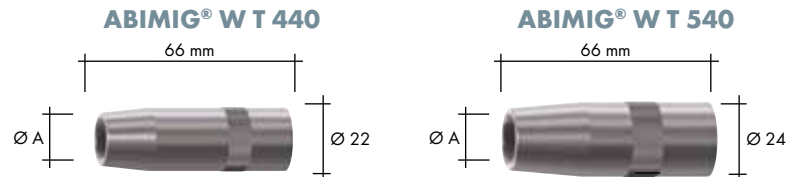

Gas nozzle incl. spatter protection

	Ø A		Ø A	
Cylindrical	Ø 18	145.0745	Ø 20	145.0742
Conical	Ø 14.5	145.D092 ¹	Ø 16	145.0735 ¹
Conical	Ø 12	145.0746	Ø 14	145.0741

Contact tip (10 pcs.)

		M8	M8
E-Cu ¹		Ø 0.8	140.0114
		Ø 1.0	140.0313
		Ø 1.2	140.0442
		Ø 1.6	140.0587
E-Cu for Al		Ø 0.8	141.0033
		Ø 1.0	141.0008
		Ø 1.2	141.0075
		Ø 1.6	141.0022
CuCrZr		Ø 0.8	140.0117
		Ø 1.0	140.0316
		Ø 1.2	140.0445
		Ø 1.6	140.0590



Contact tip holder

	X		X	
Brass	26.0	142.0252.5	25.0	142.0239.5
	28.0	142.0253.5 ¹	27.0	142.0240.5 ¹
	31.0	142.0243.5	-	-
CuCrZr	-	-	25.0	142.0247.5
	-	-	27.0	142.0248.5

¹ - Standard set-up

MIG/MAG Welding Torches "ABIMIG® W T"

ABIMIG® W T 440, ABIMIG® W T 540

Wear parts

ABIMIG® W T 440

ABIMIG® W T 540

Torch neck liner (optional) **

Steel	Ø 0.8-1.2	123.D097	123.D097
	Ø 1.4-1.6	123.D098	123.D098
Plastic liner	Ø 0.8-1.2	149.0418	149.0418
	Ø 1.4-1.6	149.0420	149.0420

Torch body insulating guides

For use with neckliners	033.D182	033.D182
For use without neckliners	033.0390	033.0390

** Requires 003.D182 insulating guide installed in torch body.

Liners



Liners for Steel Wires

Liner Steel 17' 035"-045"
Liner Steel 17' 052"-062"
Liner Steel 28' 035"-045"
Liner Steel 28' 052"-062"

Specifications

Part No.

SI-3545-17PT
SI-5262-17PT
SI-3545-28PT
SI-5262-28PT

Liners for Stainless Wires

Liner C-TFE 035"-045" 12'
Liner C-TFE 035"-045" 14'
Liner C-TFE 035"-045" 17'
Liner C-TFE 052"-062" 12'
Liner C-TFE 052"-062" 14'
Liner C-TFE 052"-062" 17'
Liner PA 035"-045" 12'
Liner PA 035"-045" 14'
Liner PA 035"-045" 17'
Liner PA 052"-062" 12'
Liner PA 052"-062" 17'
Liner PA 062"-078" 12'
Liner PA 062"-078" 17'

for 10' gun
for 12' gun
for 15' gun
for 10' gun
for 12' gun
for 15' gun
for 10' gun
for 12' gun
for 15' gun
for 10' gun
for 15' gun
for 10' gun
for 15' gun
for 10' gun
for 15' gun

127.9001
127.9002
127.9003
127.9004
127.9005
127.9006
128.9002
128.9003
128.9004
128.9005
128.9007
128.9008
128.9010

Liners for Aluminum

Liner C-TFE RD 035"-045" 12'
Liner C-TFE RD 035"-045" 14'
Liner C-TFE RD 035"-045" 17'
Liner C-TFE YW 052"-062" 12'
Liner C-TFE YW 052"-062" 14'
Liner C-TFE YW 052"-062" 17'
Collet Plastic Liner 024"-045"
Collet Plastic Liner 052"-078"
O-Ring 3.5X1.5mm

for 10' gun
for 12' gun
for 15' gun
for 10' gun
for 12' gun
for 15' gun
10 pcs.
10 pcs.
10 pcs.

126.9004
126.9005
126.9006
126.9007
126.9008
126.9009
131.0001
131.0002
165.0008
129.XXXX
191.0001

Liner Support (for plastic liners) Specify Feeder
Contact Tip Wrench

BINZEL, S.A. DE C.V.
Municipio de Pabellon de Arteaga 102
Valle de Aguascalientes, 20358
San Francisco de los Romo, Ags. MX
Tel: +52(499) 9730133
Fax: +52(449) 9731388
info@binzel.com.mx

Alexander Binzel Corporation
650 Medimmune Ct., Suite 110
Frederick, MD 21703-8619
Tel: 301.846.4196
Fax: 301.846.4497
customerservice@abicorusa.com



www.binzel-abicor.com