

MIG/MAG Welding Torch Push-Pull *Plus*



The "long-range torch" with the *Plus* ...

The welding torches of the Push-Pull *Plus* series – especially developed for aluminium welding requirements and the use of thin wires – makes problem-free and constant wire feed possible, even with longer cable assemblies. A powerful sturdy pull motor with potentiometer guarantees exact speed regulation. For an optimum wire feed without frictional loss, the contact pressure of the feeding rollers can be regulated precisely and easily directly on the handle. The ergonomic handle ensures optimum and low-fatigue handling.

The screw-type torch necks can be replaced quickly. They are available as either straight or 45° angled versions. A special interface between the handle and the torch neck makes it possible to turn the necks by up to 360°. All torches, air and liquid cooled for capacities of up to 400 A, are based on the tried-and-trusted "MB" torch neck structure.

The main areas of application for these welding torches include shipbuilding, container and tank manufacture etc., as well as construction of automobile and railway vehicles. Wherever exact and constant wire feeding is absolutely essential.

The features:

- Constant and problem-free wire feeding thanks to a powerful pull motor
- Precise contact pressure regulation of the wire feeding rollers directly on the torch
- Optionally available with potentiometer for speed regulation
- Wearing parts are identical to those of the tried-and-trusted MB torch series – minimised stocking
- Optimum torch cooling – long tool lives
- Sturdy design – long service life



System overview

MIG/MAG Welding Torches Push-Pull Plus

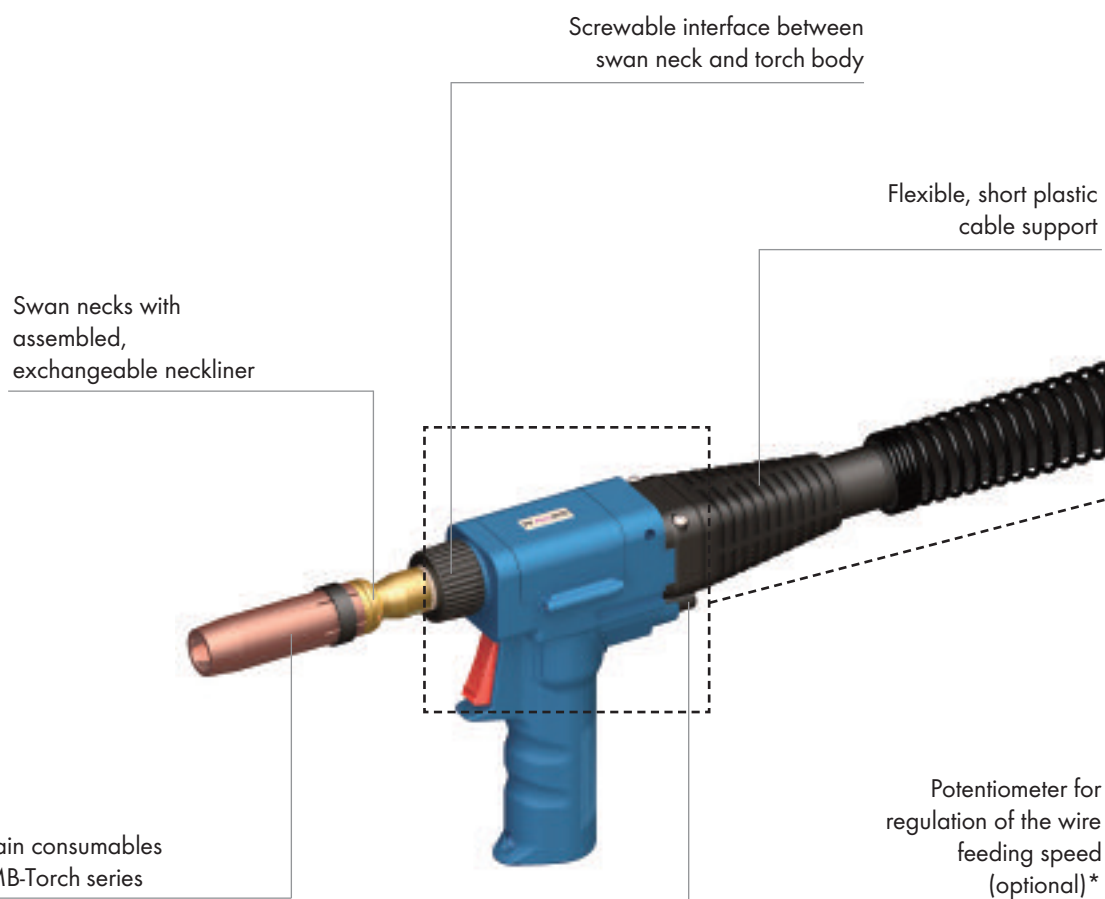

Technical data (EN 60 974-7):

MIG/MAG Welding Torch Push-Pull Plus

Type	Cooling	Rating (A)		Duty cycle (%)	Wire-Ø (mm)
		CO ₂	Mixed Gases M21		
Push-Pull Plus 36 D	air	300	270	60	0.8-1.2
Push-Pull Plus 240 D	liquid**	270	240	100	0.8-1.2
Push-Pull Plus 401 D	liquid**	400	350	100	0.8-1.6

*For complete torches with potentiometer we need the additional indication of the required resistance value.

General advice:

At pulsed arc the duty cycles decrease up to 35%.

**To protect the cable assembly components from excessive heat build up we recommend a post welding cooling cycle of at least four minutes.

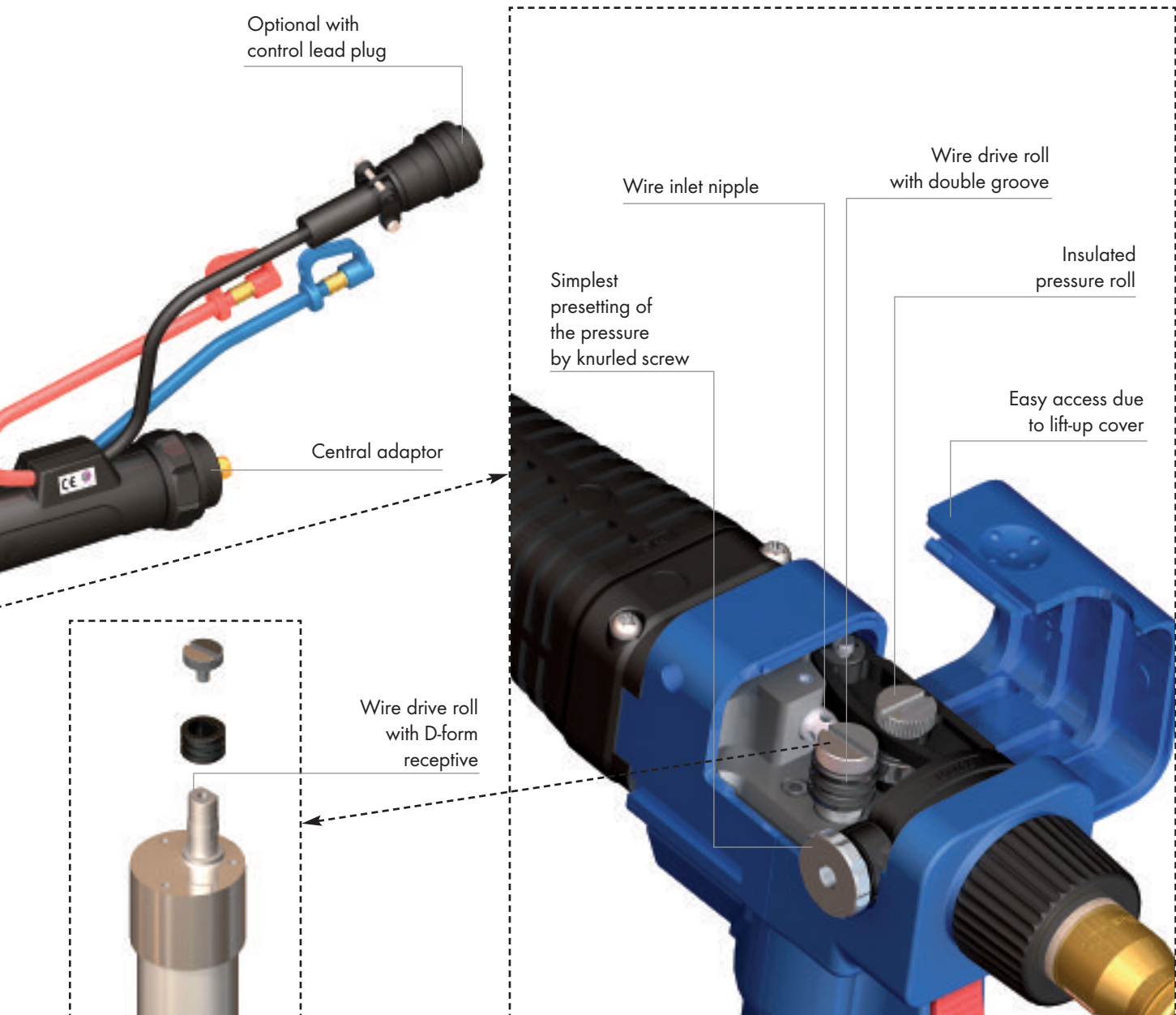

Order advice:

The initial equipment of the complete torches Push-Pull *Plus* contains the following wear parts:

Wear parts for Push-Pull <i>Plus</i>	36 D	240 D	401 D
Description	Part-No.	Part-No.	Part-No.
Contact tip holder (short)	142.0020	142.0003	142.0022
Gas diffuser	014.0261	012.0183	030.0145
Contact tip E-Cu; Ø 1.2	140.0442	140.0379	140.0442
Gas nozzle, conical	145.0078	145.0080	145.0085
Neckliner*	Pos. 16 and 17	Pos. 16 and 17	Pos. 16 and 17
PA liner	128.0019	128.0019	128.0019
Wire drive roll Ø 1.2 / 1.2	095.0066.1	095.0066.1	095.0066.1

Other wear parts can be ordered separately.

*Find Pos. 16 and 17 on the following pages.

Push-Pull *Plus* 36 D air cooled

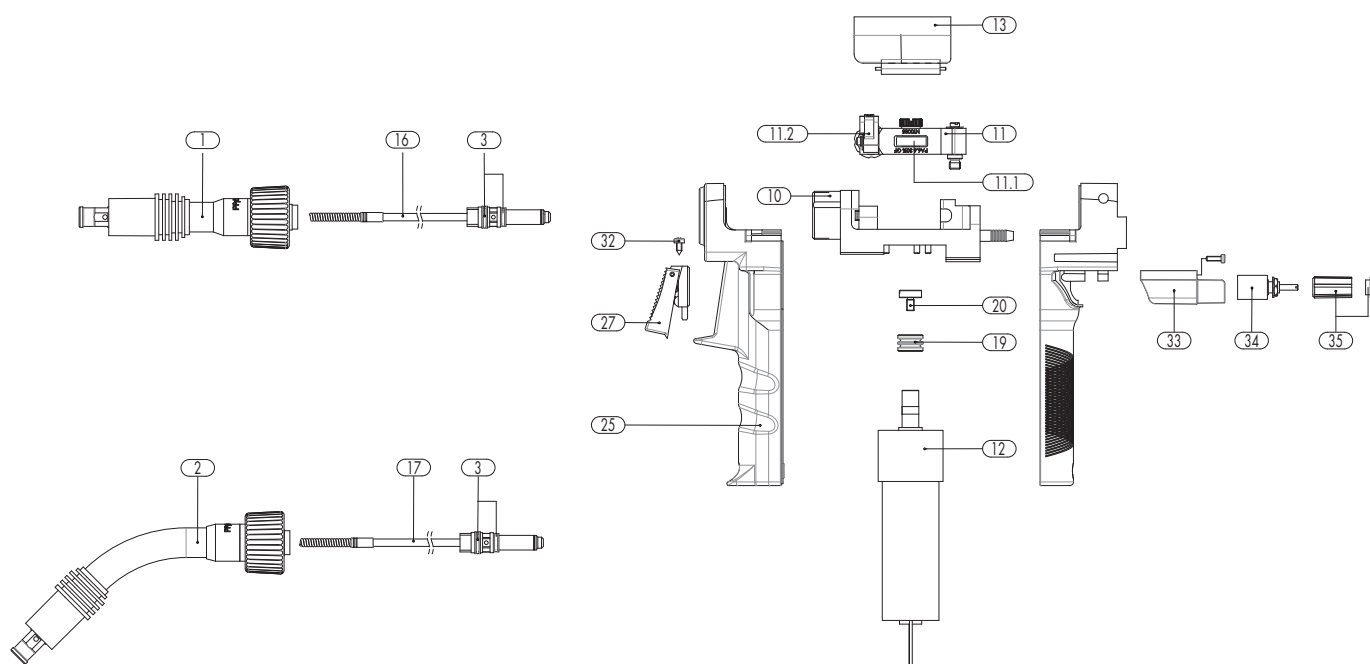

Component	Pos.	Description	Indication	Part-No.
Push-Pull <i>Plus</i> torch complete	not ill.	Push-Pull <i>Plus</i> 36 D; straight; 40 V motor; GZ-2, 8.00 m		085.0104.1
		Push-Pull <i>Plus</i> 36 D; 45° bent; 40 V motor; GZ-2, 8.00 m		085.0105.1
		Push-Pull <i>Plus</i> 36 D; straight; 40 V motor; poti 10 kΩ; GZ-2, 8.00 m		085.0106.1
		Push-Pull <i>Plus</i> 36 D; 45° bent; 40 V motor; poti 10 kΩ; GZ-2, 8.00 m		085.0107.1
Torch neck	1	Torch neck Push-Pull <i>Plus</i> 36 D; straight		085.0116.1
	2	Torch neck Push-Pull <i>Plus</i> 36 D; 45° bent		085.0117.1
	3	Wear parts set gasket rings	5 pcs.	085.0029
Torch body, gear motor and equipment	10	Torch adaptor cpl.		085.0019
	11	Pressure trigger cpl.		085.0018
	11.1	Pressure roll		085.0042
	11.2	Pressure button cpl.		085.0043
	12	Gear motor 24 V DC incl. Pos. 19 (Wire-Ø 1.2 mm) and Pos. 20		085.0102.1
		Gear motor 40 V DC incl. Pos. 19 (Wire-Ø 1.2 mm) and Pos. 20		085.0103.1
	13	Cover cpl.		400.1186
	16	Neckliner Combi for Push-Pull <i>Plus</i> 36 D for Wire-Ø 0.8-1.0 mm	L=145 mm	149.0260.3
		Neckliner Combi for Push-Pull <i>Plus</i> 36 D for Wire-Ø 1.2-1.6 mm	L=145 mm	149.0261.3
	17	Neckliner Combi for Push-Pull <i>Plus</i> 36 D 45° for Wire-Ø 0.8-1.0 mm	L=197 mm	149.0262.3
		Neckliner Combi for Push-Pull <i>Plus</i> 36 D 45° for Wire-Ø 1.2-1.6 mm	L=197 mm	149.0263.3
	19	Wire drive roll for Wire-Ø 0.8 mm	universal	095.0064.1
	Wire drive roll for Wire-Ø 1.0 mm	universal	095.0065.1	
	Wire drive roll for Wire-Ø 1.2 mm	universal	095.0066.1	
20	Knurled screw M4		085.0113.5	
Handle	25	Handle cpl. incl. mounting screws and extension material		085.0017
	27	Trigger 2-pole		185.0100
	32	Sheet metal screw 2.9x6.5	20 pcs.	079.0003
	33	Potentiometer housing cpl.		085.0016
	34	Potentiometer	1.0 kΩ	187.0077
	Potentiometer	2.0 kΩ	187.0078	

Push-Pull Plus 36 D air cooled

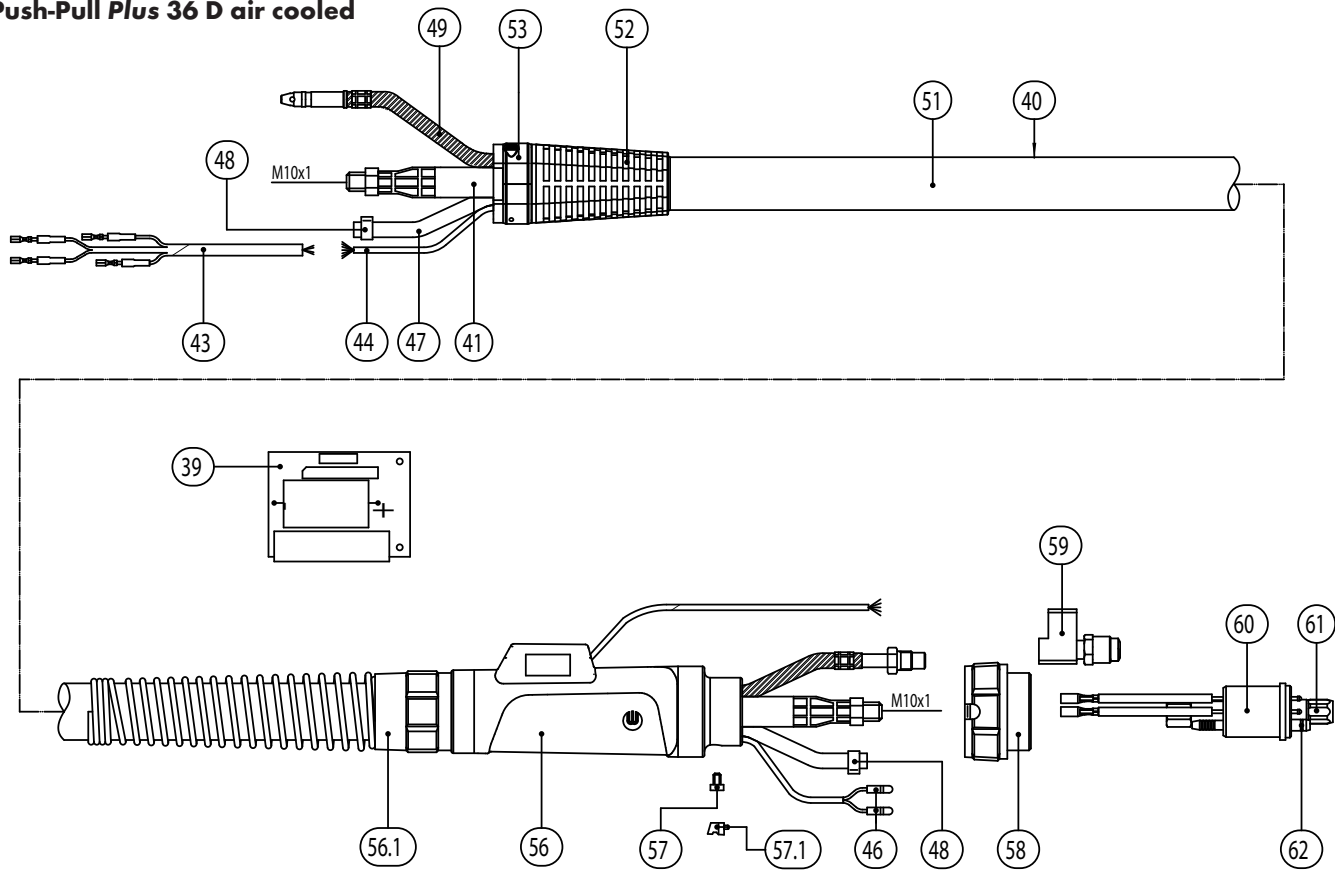

Component	Pos.	Description	Indication	Part-No.
Handle	34	Potentiometer	5.5 kΩ	187.0076
		Potentiometer	10.0 kΩ	187.0075
		Potentiometer	20.0 kΩ	187.0079
	35	Potentiometer knob cpl.		085.0041
Printed circuit board	39	Printed circuit board		080.0009
Cable assemblies	40	Cable assembly cpl. for 8.0 m with 7-pole control leads without central adaptor GZ-2		085.0040
	41	Power cable cpl. Typ 35		118.0074
	43	Control lead cpl. 4-pole 0.4 m	0.4 m	101.0054
	44	Control lead 7-pole 0.34 qmm	100 m	100.0034
	46	Plug	20 pcs.	175.0004
	47	Hose 30 black Ø 4.9x1.5 mm	100 m	109.0040
	48	Hose clamp Ø 8.2 mm	100 pcs.	173.0005
	49	Wire conduit cpl. for 8.0 m		156.0273
	51	Fabrics hose 28x1.5 mm	40 m	107.0091
	52	Cable support		400.1188
	53	Cable support fastening cpl.		400.1247
	56	Cable support machine side big cpl. ND 31		500.0342
	56.1	Cable support spring big ND 31		500.0274
	57	Pan head screw M4x6	20 pcs.	000.0552
	57.1	Sealing cap	20 pcs.	500.0251
	58	Adaptor nut M33x2		500.0213
	59	Powerfitting cpl. M14x1		500.0460
	60	Central adaptor GZ-2 M14x1		501.0018
	61	Coupling nut M10x1		501.D536.5
	62	O-ring 4x1	20 pcs.	165.0002
Wear parts	72	Gas diffuser, white	10 pcs.	014.0261
		Gas diffuser, long life	10 pcs.	014.0026
		Gas diffuser, ceramic	10 pcs.	014.0023

Push-Pull Plus 36 D air cooled

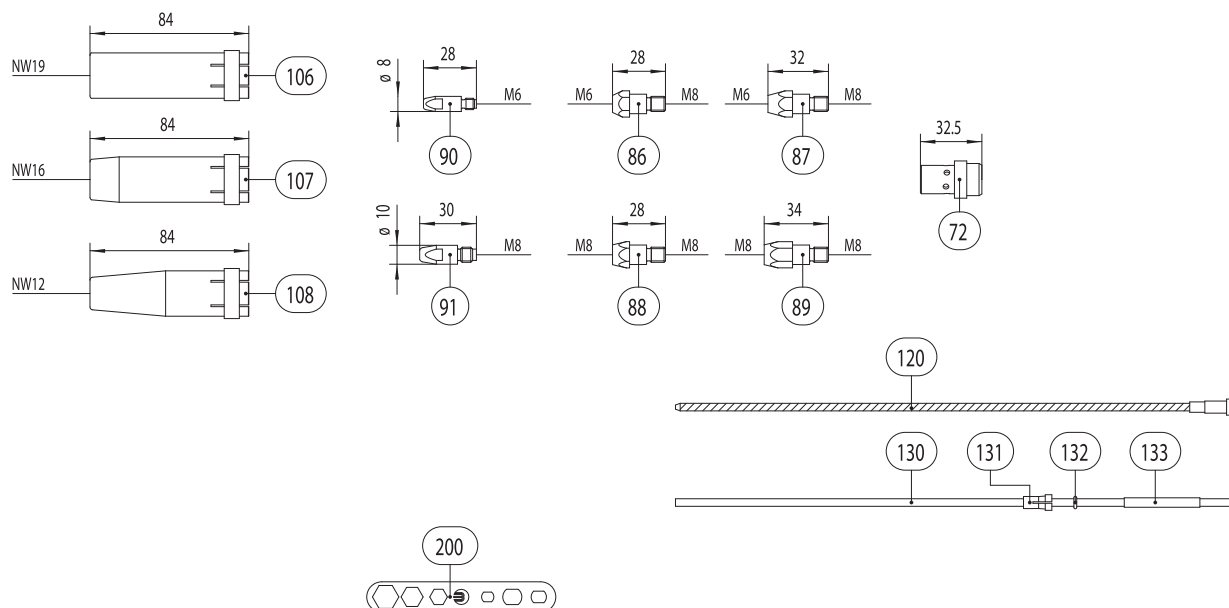

Component	Pos.	Description	Indication	Part-No.
Wear parts	86	Contact tip holder M6; 28.0 mm (short)	10 pcs.	142.0005
	87	Contact tip holder M6; 32.0 mm (long)	10 pcs.	142.0011
	88	Contact tip holder M8; 28.0 mm (short)	10 pcs.	142.0020
	89	Contact tip holder M8; 34.0 mm (long)	10 pcs.	142.0024
	90	Contact tip M6 E-Cu; Ø 0.8 (8x28)	10 pcs.	140.0051
		Contact tip M6 E-Cu; Ø 1.0 (8x28)	10 pcs.	140.0242
		Contact tip M6 E-Cu; Ø 1.2 (8x28)	10 pcs.	140.0379
		Contact tip M6 CuCrZr; Ø 0.8 (8x28)	10 pcs.	140.0054
		Contact tip M6 CuCrZr; Ø 1.0 (8x28)	10 pcs.	140.0245
		Contact tip M6 CuCrZr; Ø 1.2 (8x28)	10 pcs.	140.0382
		Contact tip M6 E-Cu; Ø 0.8 for alu wire (8x28)	10 pcs.	141.0001
		Contact tip M6 E-Cu; Ø 1.0 for alu wire (8x28)	10 pcs.	141.0006
		Contact tip M6 E-Cu; Ø 1.2 for alu wire (8x28)	10 pcs.	141.0010
	91	Contact tip M8 E-Cu; Ø 0.8 (10x30)	10 pcs.	140.0114
		Contact tip M8 E-Cu; Ø 1.0 (10x30)	10 pcs.	140.0313
		Contact tip M8 E-Cu; Ø 1.2 (10x30)	10 pcs.	140.0442
		Contact tip M8 CuCrZr; Ø 0.8 (10x30)	10 pcs.	140.0117
		Contact tip M8 CuCrZr; Ø 1.0 (10x30)	10 pcs.	140.0316
		Contact tip M8 CuCrZr; Ø 1.2 (10x30)	10 pcs.	140.0445
		Contact tip M8 E-Cu; Ø 0.8 for alu wire (10x30)	10 pcs.	141.0003
		Contact tip M8 E-Cu; Ø 1.0 for alu wire (10x30)	10 pcs.	141.0008
		Contact tip M8 E-Cu; Ø 1.2 for alu wire (10x30)	10 pcs.	141.0015
		106 Gas nozzle; cylindrical; NW Ø 19.0	10 pcs.	145.0045
		107 Gas nozzle; conical; NW Ø 16.0	10 pcs.	145.0078
		108 Gas nozzle; conical; NW Ø 12.0	10 pcs.	145.0126
		120 Guide spiral liner blank; 2.0/4.5; Wire-Ø 0.8-1.2; for 8.00 m		122.0040
		Guide spiral liner insulated; 2.0/4.5; Wire-Ø 0.8-1.2; for 8.00 m		124.0169
	130 PTFE core liner 2.0/4.0; red; Wire-Ø 0.8-1.2; for 8.00 m		126.0030	

Component	Pos.	Description	Indication	Part-No.
Wear parts	130	PTFE carbon core liner 2.0/4.0; Wire-Ø 0.8- 1.2; for 8.00 m		127.0009
		Polyamid core liner 2.0/4.0; Wire-Ø 0.8- 1.2; for 8.00 m		128.0019
	131	Nipple for core liner at 4.0	20 pcs.	131.0001
	132	O-ring 3.5x1.5	20 pcs.	165.0008
	133	Guide tube for core liners up to 4.0 (200 mm)		129.0461
	200	Spanner		191.0001

Push-Pull *Plus* 240 D liquid cooled

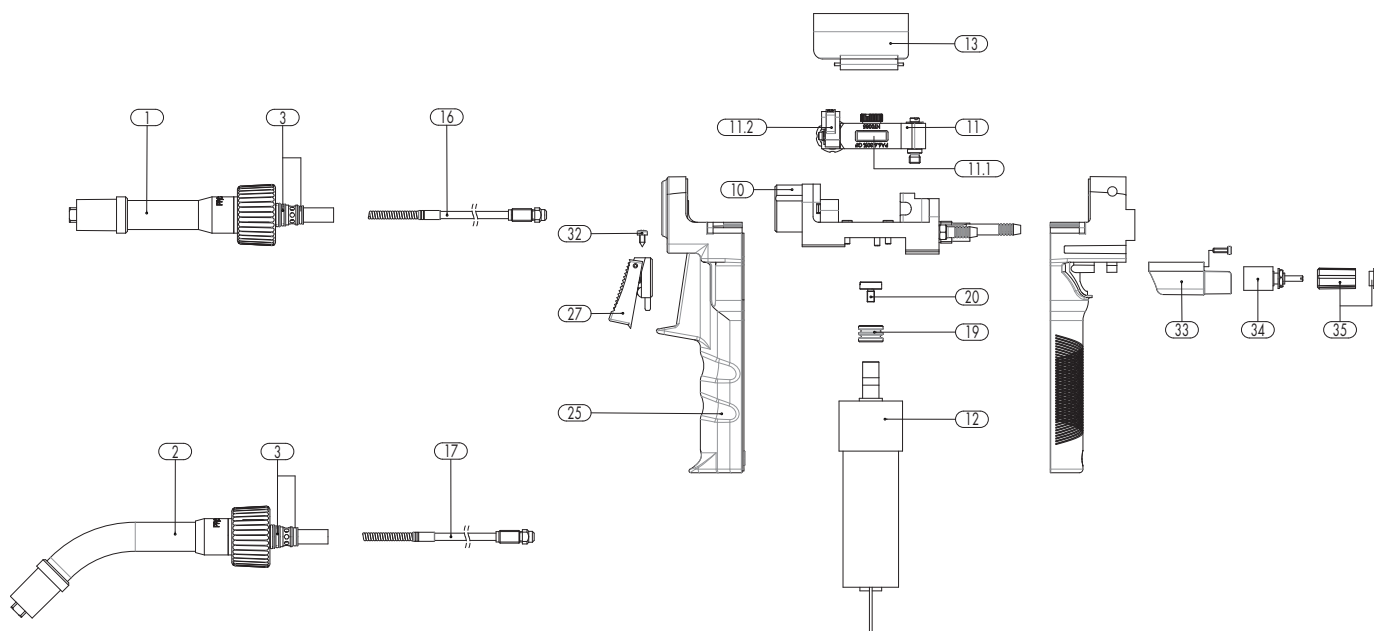

Component	Pos.	Description	Indication	Part-No.
Push-Pull <i>Plus</i> torch complete	not ill.	Push-Pull <i>Plus</i> 240 D; straight; 40 V motor; WZ-2, 8.00 m		095.0110.1
		Push-Pull <i>Plus</i> 240 D; 45° bent; 40 V motor; WZ-2, 8.00 m		095.0111.1
		Push-Pull <i>Plus</i> 240 D; straight; 40 V motor; poti 10 kΩ; WZ-2, 8.00 m		095.0119.1
		Push-Pull <i>Plus</i> 240 D; 45° bent; 40 V motor; poti 10 kΩ; WZ-2, 8.00 m		095.0120.1
Torch neck	1	Torch neck Push-Pull <i>Plus</i> 240 D; straight		095.0040.1
	2	Torch neck Push-Pull <i>Plus</i> 240 D; 45° bent		095.0052.1
	3	Wear parts set gasket rings	5 pcs.	095.0001
Torch body, gear motor and equipment	10	Torch adaptor cpl.		095.0032
	11	Pressure trigger cpl.		085.0018
	11.1	Pressure roll		085.0042
	11.2	Pressure button cpl.		085.0043
	12	Gear motor 24 V DC incl. Pos. 19 (Wire-Ø 1.2 mm) and Pos. 20		085.0102.1
		Gear motor 40 V DC incl. Pos. 19 (Wire-Ø 1.2 mm) and Pos. 20		085.0103.1
	13	Cover cpl.		095.0072.1
	16	Neckliner Combi for Push-Pull <i>Plus</i> 240 D for Wire-Ø 0.8 - 1.2 mm	L=135 mm	149.0264.3
		Neckliner Combi for Push-Pull <i>Plus</i> 240 D for Wire-Ø 1.2 - 1.6 mm	L=135 mm	149.0265.3
	17	Neckliner Combi for Push-Pull <i>Plus</i> 240 D 45° for Wire-Ø 0.8 - 1.0 mm	L=195 mm	149.0266.3
		Neckliner Combi for Push-Pull <i>Plus</i> 240 D 45° for Wire-Ø 1.2 - 1.6 mm	L=195 mm	149.0267.3
19	Wire drive roll for Wire-Ø 0.8 mm	universal	095.0064.1	
	Wire drive roll for Wire-Ø 1.0 mm	universal	095.0065.1	
	Wire drive roll for Wire-Ø 1.2 mm	universal	095.0066.1	
20	Knurled screw M4		085.0113.5	
Handle	25	Handle cpl. incl. mounting screws and extension material		085.0017
	27	Trigger 2-pole		185.0100
	32	Sheet metal screw 2.9x6.5	20 pcs.	079.0003
	33	Potentiometer housing cpl.		085.0016
	34	Potentiometer	1.0 kΩ	187.0077
	Potentiometer	2.0 kΩ	187.0078	

Push-Pull Plus 240 D liquid cooled

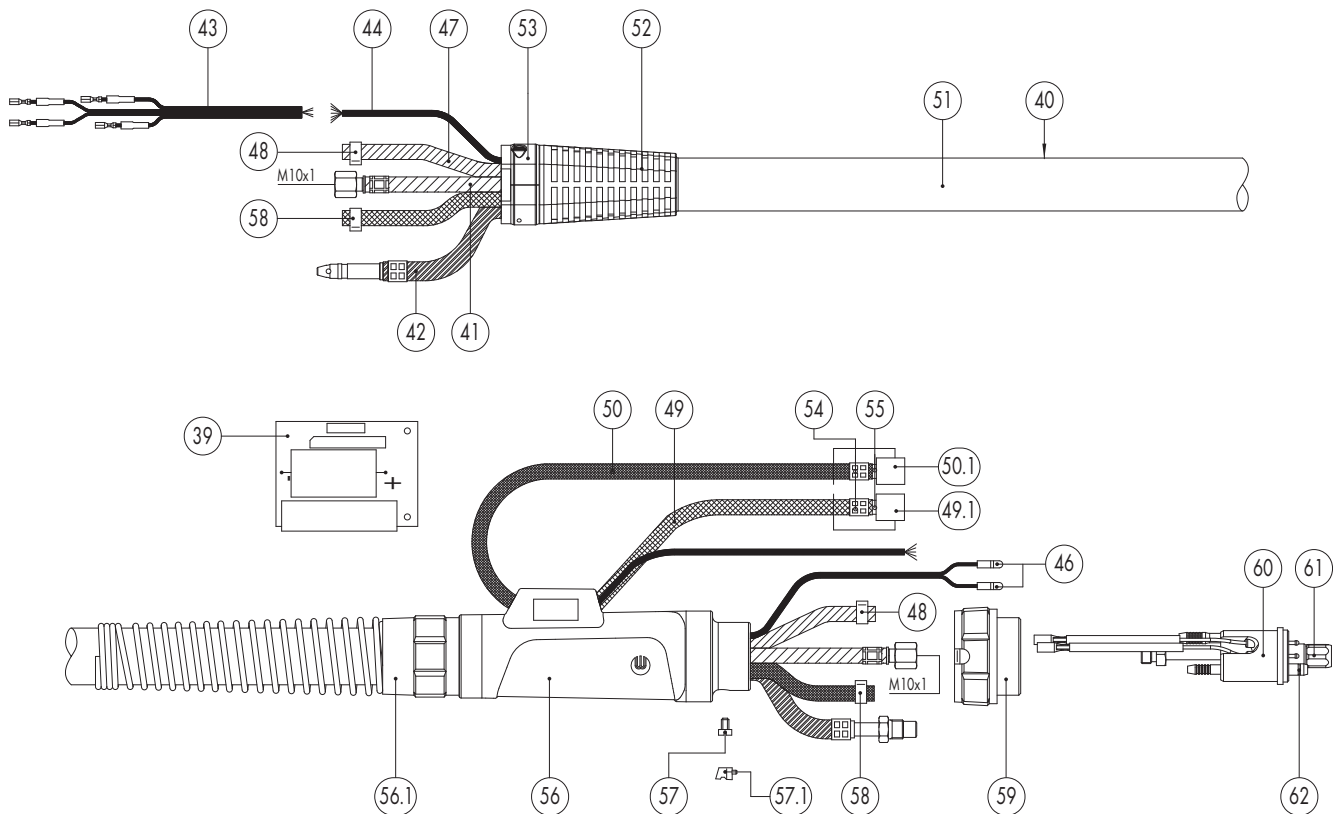

Component	Pos.	Description	Indication	Part-No.
Handle	34	Potentiometer	5.5 kΩ	187.0076
		Potentiometer	10.0 kΩ	187.0075
		Potentiometer	20.0 kΩ	187.0079
	35	Potentiometer knob cpl.		085.0041
Printed circuit board	39	Printed circuit board		080.0009
Cable assemblies and wear parts	40	Cable assembly cpl. for 8.00 m with 7-pole control leads without central adaptor WZ-2		095.0031
	41	Power cable cpl. (PVC) for 8.00 m		115.0043
	42	Wire conduit cpl. for 8.00 m		156.0273
	43	Control lead cpl. 4-pole 0.4 m	0.4 m	101.0054
	44	Control lead 7-pole 0.34 qmm	100 m	100.0034
	46	Plug	20 pcs.	175.0004
	47	Hose 30 black Ø 4.9x1.5 mm	100 m	109.0040
	48	Hose clamp Ø 8.2 mm	100 pcs.	173.0005
	49	Hose 47 blue Ø 5.5x1.5	100 m	109.0057
	49.1	Fastener cap blue		501.2424
	50	Water hose 0.60 m		103.0114
	50.1	Fastener cap red		501.2423
	51	Fabrics hose 28x1.5 mm	40 m	107.0091
	52	Cable support		400.1188
	53	Cable support fastening cpl.		400.1247
	54	Hose clamp Ø 9.0	100 pcs.	173.0001
	55	Plug nipple ND 5 mm / Ø 6.0		501.0114
	56	Cable support machine side big cpl. ND 31		500.0342
	56.1	Cable support spring big ND 31		500.0274
	57	Pan head screw M4x6	20 pcs.	000.0552
	57.1	Sealing cap	20 pcs.	500.0251
	58	Hose clamp Ø 9.5 mm	100 pcs.	173.0002
	59	Adaptor nut M33x2		500.0213

Push-Pull Plus 240 D liquid cooled

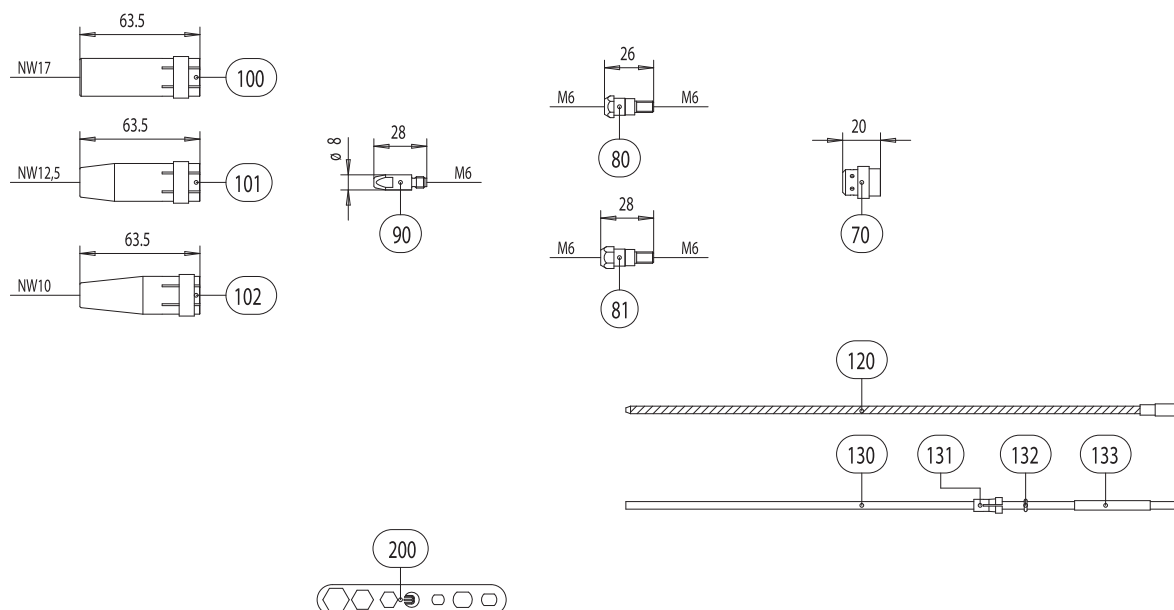

Component	Pos.	Description	Indication	Part-No.
Cable assemblies and wear parts	60	Central adaptor WZ-2 M10x1		501.0015
	61	Coupling nut M10x1	10 pcs.	501.0082
	62	O-ring 4x1	20 pcs.	165.0002
Wear parts	70	Gas diffuser, white	10 pcs.	012.0183
		Gas diffuser, silicon	10 pcs.	012.0243
	80	Contact tip holder M6; 26.0 mm	10 pcs.	142.0003
	81	Contact tip holder M6; 28.0 mm	10 pcs.	142.0010
	90	Contact tip M6 E-Cu; Ø 0.8 (8x28)	10 pcs.	140.0051
		Contact tip M6 E-Cu; Ø 1.0 (8x28)	10 pcs.	140.0242
		Contact tip M6 E-Cu; Ø 1.2 (8x28)	10 pcs.	140.0379
		Contact tip M6 CuCrZr; Ø 0.8 (8x28)	10 pcs.	140.0054
		Contact tip M6 CuCrZr; Ø 1.0 (8x28)	10 pcs.	140.0245
		Contact tip M6 CuCrZr; Ø 1.2 (8x28)	10 pcs.	140.0382
		Contact tip M6 E-Cu; Ø 0.8 for alu wire (8x28)	10 pcs.	141.0001
		Contact tip M6 CuCrZr silver plated; Ø 0.8 (8x28)	10 pcs.	147.0054
		Contact tip M6 E-Cu; Ø 1.0 for alu wire (8x28)	10 pcs.	141.0006
		Contact tip M6 E-Cu; Ø 1.2 for alu wire (8x28)	10 pcs.	141.0010
		Contact tip M6 CuCrZr silver plated; Ø 1.0 (8x28)	10 pcs.	147.0245
		Contact tip M6 CuCrZr silver plated; Ø 1.2 (8x28)	10 pcs.	147.0382
	100	Gas nozzle; cylindrical; NW Ø 17.0	10 pcs.	145.0047
	101	Gas nozzle; conical; NW Ø 12.5	10 pcs.	145.0080
	102	Gas nozzle; conical; NW Ø 10.0	10 pcs.	145.0128
	120	Guide spiral liner blank; 2.0/4.5; Wire-Ø 0.8-1.2; for 8.00 m		122.0040
	130	PTFE core liner 2.0/4.0; red; Wire-Ø 0.8-1.2; for 8.00 m		126.0030
	131	PTFE carbon core liner 2.0/4.0; Wire-Ø 0.8-1.2; for 8.00 m		127.0009
		Polyamid core liner 2.0/4.0; Wire-Ø 0.8-1.2; for 8.00 m		128.0019
	Nipple for core liner at 4.0	20 pcs.	131.0001	
132	O-ring 3.5x1.5	20 pcs.	165.0008	

Component	Pos.	Description	Indication	Part-No.
Wear parts	133	Guide tube for core liners up to 4.0 (200 mm)		129.0461
	200	Spanner		191.0001

Push-Pull *Plus* 401 D liquid cooled

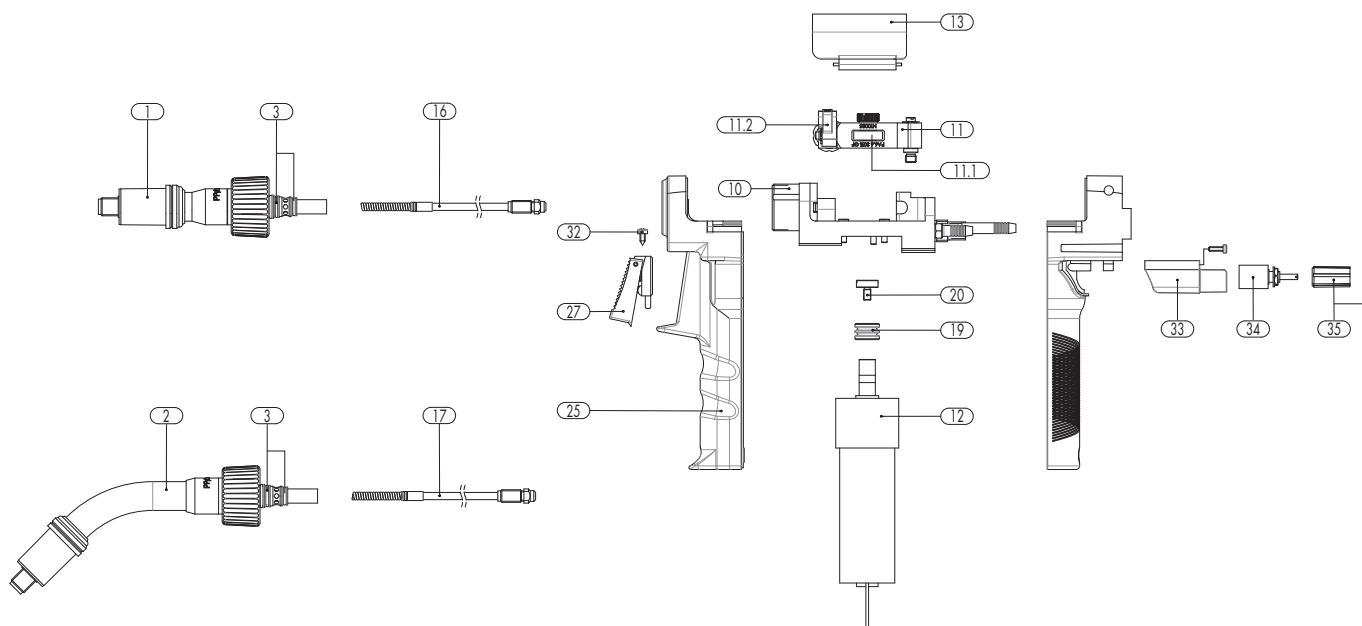

Component	Pos.	Description	Indication	Part-No.
Push-Pull <i>Plus</i> torch complete	not ill.	Push-Pull <i>Plus</i> 401 D; straight; 40 V motor; WZ-2, 8.00 m		095.0100.1
		Push-Pull <i>Plus</i> 401 D; 45° bent; 40 V motor; WZ-2, 8.00 m		095.0101.1
		Push-Pull <i>Plus</i> 401 D; straight; 40 V motor; poti 10 kΩ; WZ-2, 8.00 m		095.0114.1
		Push-Pull <i>Plus</i> 401 D; 45° bent; 40 V motor; poti 10 kΩ; WZ-2, 8.00 m		095.0115.1
Torch neck	1	Torch neck Push-Pull <i>Plus</i> 401 D; straight		095.0002
	2	Torch neck Push-Pull <i>Plus</i> 401 D; 45° bent		095.0015
	3	Wear parts set gasket rings	5 pcs.	095.0001
Torch body, gear motor and equipment	10	Torch adaptor cpl.		095.0032
	11	Pressure trigger cpl.		085.0018
	11.1	Pressure roll		085.0042
	11.2	Pressure button cpl.		085.0043
	12	Gear motor 24 V DC incl. Pos. 19 (Wire-Ø 1.2 mm) and Pos. 20		085.0102.1
		Gear motor 40 V DC incl. Pos. 19 (Wire-Ø 1.2 mm) and Pos. 20		085.0103.1
	13	Cover cpl.		095.0009
	16	Neckliner Combi for Push-Pull <i>Plus</i> 401 D for Wire-Ø 0.8-1.0 mm	L=135 mm	149.0264.3
		Neckliner Combi for Push-Pull <i>Plus</i> 401 D for Wire-Ø 1.2-1.6 mm	L=135 mm	149.0265.3
	17	Neckliner Combi for Push-Pull <i>Plus</i> 401 D 45° for Wire-Ø 0.8-1.0 mm	L=195 mm	149.0266.3
		Neckliner Combi for Push-Pull <i>Plus</i> 401 D 45° for Wire-Ø 1.2-1.6 mm	L=195 mm	149.0267.3
	19	Wire drive roll for Wire-Ø 0.8 mm	universal	095.0064.1
		Wire drive roll for Wire-Ø 1.0 mm	universal	095.0065.1
	Wire drive roll for Wire-Ø 1.2 mm	universal	095.0066.1	
	Wire drive roll for Wire-Ø 1.6 mm	universal	095.0067.1	
20	Knurled screw M4	universal	085.0113.5	
Handle	25	Handle cpl. incl. mounting screws and extension material		085.0017
	27	Trigger 2-pole		185.0100
	32	Sheet metal screw 2.9x6.5	20 pcs.	079.0003
	33	Potentiometer housing cpl.		085.0016
	34	Potentiometer	1.0 kΩ	187.0077

Push-Pull Plus 401 D liquid cooled

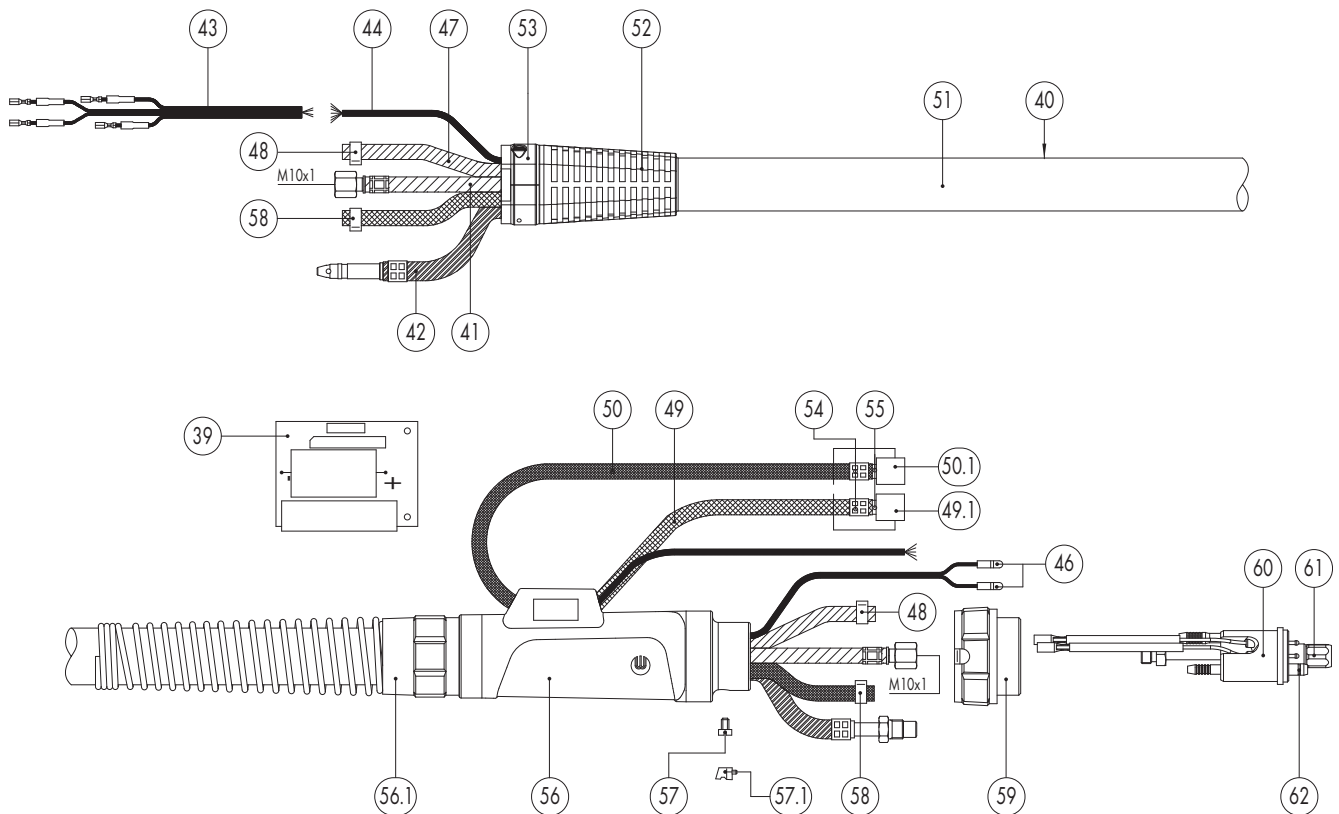

Component	Pos.	Description	Indication	Part-No.
Handle	34	Potentiometer	2.0 kΩ	187.0078
		Potentiometer	5.5 kΩ	187.0076
		Potentiometer	10.0 kΩ	187.0075
		Potentiometer	20.0 kΩ	187.0079
	35	Potentiometer knob cpl.		085.0041
Printed circuit board	39	Printed circuit board		080.0009
Cable assemblies and wear parts	40	Cable assembly cpl. for 8.00 m with 7-pole control leads without Central adaptor WZ-2		095.0031
	41	Power cable cpl. (PVC) for 8.00 m		115.0043
	42	Wire conduit cpl. for 8.00 m		156.0273
	43	Control lead cpl. 4-pole 0.4 m	0.4 m	101.0054
	44	Control lead 7-pole 0.34 qmm	100 m	100.0034
	46	Plug	20 pcs.	175.0004
	47	Hose 30 black Ø 4.9x1.5 mm	100 m	109.0040
	48	Hose clamp Ø 8.2 mm	100 pcs.	173.0005
	49	Hose 47 blue Ø 5.5x1.5	100 m	109.0057
	49.1	Fastener cap blue		501.2424
	50	Water hose 0.60 m		103.0114
	50.1	Fastener cap red		501.2423
	51	Fabrics hose 28x1.5 mm	40 m	107.0091
	52	Cable support		400.1188
	53	Cable support fastening cpl.		400.1247
	54	Hose clamp Ø 9.0	100 pcs.	173.0001
	55	Plug nipple ND 5 mm / Ø 6.0		501.0114
	56	Cable support machine side big cpl.		500.0342
	56.1	Cable support spring big ND 31		500.0274
	57	Pan head screw M4x6	20 pcs.	000.0552
	57.1	Sealing cap	20 pcs.	500.0251
	58	Hose clamp Ø 9.5 mm		173.0002

Push-Pull Plus 401 D liquid cooled

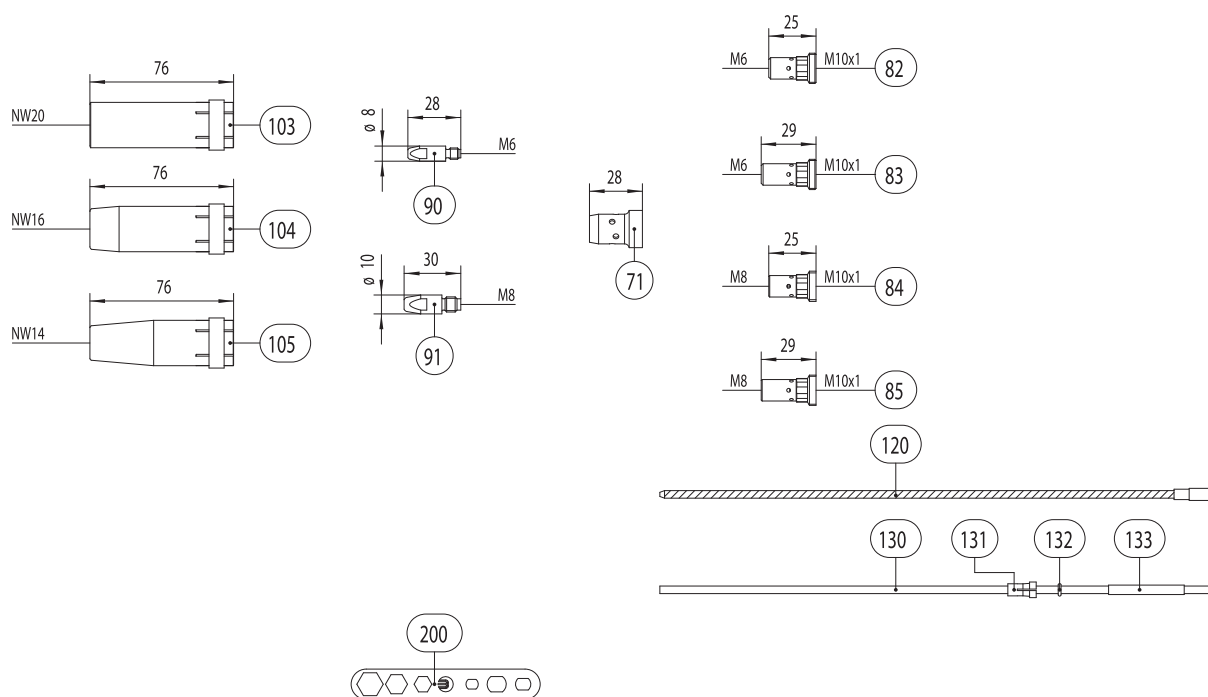

Component	Pos.	Description	Indication	Part-No.
Cable assemblies and wear parts	59	Adaptor nut M33x2		500.0213
	60	Central adaptor WZ-2 M10x1		501.0015
	61	Coupling nut M10x1		501.D536.5
	62	O-ring 4x1	20 pcs.	165.0002
Wear parts	71	Gas diffuser, white	10 pcs.	030.0145
		Gas diffuser, long life	10 pcs.	030.0037
		Gas diffuser, ceramic	10 pcs.	030.0190
	82	Contact tip holder M6; 25.0 mm (short)	10 pcs.	142.0008
	83	Contact tip holder M6; 29.0 mm (long)	10 pcs.	142.0013
	84	Contact tip holder M8; 25.0 mm (short)	10 pcs.	142.0022
	85	Contact tip holder M8; 29.0 mm (long)	10 pcs.	142.0027
	90	Contact tip M6 E-Cu; Ø 0.8 (8x28)	10 pcs.	140.0051
		Contact tip M6 E-Cu; Ø 1.0 (8x28)	10 pcs.	140.0242
		Contact tip M6 E-Cu; Ø 1.2 (8x28)	10 pcs.	140.0379
		Contact tip M6 E-Cu; Ø 1.4 (8x28)	10 pcs.	140.0516
		Contact tip M6 E-Cu; Ø 1.6 (8x28)	10 pcs.	140.0555
		Contact tip M6 CuCrZr; Ø 0.8 (8x28)	10 pcs.	140.0054
		Contact tip M6 CuCrZr; Ø 1.0 (8x28)	10 pcs.	140.0245
		Contact tip M6 CuCrZr; Ø 1.2 (8x28)	10 pcs.	140.0382
		Contact tip M6 CuCrZr; Ø 1.4 (8x28)	10 pcs.	140.0519
		Contact tip M6 CuCrZr; Ø 1.6 (8x28)	10 pcs.	140.0558
		Contact tip M6 E-Cu; Ø 0.8 for alu wire (8x28)	10 pcs.	141.0001
		Contact tip M6 E-Cu; Ø 1.0 for alu wire (8x28)	10 pcs.	141.0006
		Contact tip M6 E-Cu; Ø 1.2 for alu wire (8x28)	10 pcs.	141.0010
	90	Contact tip M6 E-Cu; Ø 1.6 for alu wire (8x28)	10 pcs.	141.0020
	91	Contact tip M8 E-Cu; Ø 0.8 (10x30)	10 pcs.	140.0114
		Contact tip M8 E-Cu; Ø 1.0 (10x30)	10 pcs.	140.0313
	Contact tip M8 E-Cu; Ø 1.2 (10x30)		140.0442	

Component	Pos.	Description	Indication	Part-No.
Wear parts	91	Contact tip M8 E-Cu; Ø 1.4 (10x30)		140.0533
		Contact tip M8 E-Cu; Ø 1.6 (10x30)	10 pcs.	140.0587
		Contact tip M8 CuCrZr; Ø 0.8 (10x30)	10 pcs.	140.0117
		Contact tip M8 CuCrZr; Ø 1.0 (10x30)	10 pcs.	140.0316
		Contact tip M8 CuCrZr; Ø 1.2 (10x30)	10 pcs.	140.0445
		Contact tip M8 CuCrZr; Ø 1.4 (10x30)	10 pcs.	140.0536
		Contact tip M8 CuCrZr; Ø 1.6 (10x30)	10 pcs.	140.0590
		Contact tip M8 E-Cu; Ø 0.8 for alu wire (10x30)	10 pcs.	141.0003
		Contact tip M8 E-Cu; Ø 1.0 for alu wire (10x30)	10 pcs.	141.0008
		Contact tip M8 E-Cu; Ø 1.2 for alu wire (10x30)	10 pcs.	141.0015
		Contact tip M8 E-Cu; Ø 1.6 for alu wire (10x30)	10 pcs.	141.0022
	103	Gas nozzle; cylindrical; NW Ø 20.0	10 pcs.	145.0051
	104	Gas nozzle; conical; NW Ø 16.0	10 pcs.	145.0085
	105	Gas nozzle; conical; NW Ø 14.0	10 pcs.	145.0132
	120	Guide spiral liner blank; 2.0/4.5; Wire-Ø 0.8-1.2; for 8.00 m		122.0040
		Guide spiral liner insulated; 2.0/4.5; Wire-Ø 0.8-1.2; for 8.00 m		124.0169
		Guide spiral liner blank; 2.5/4.5; Wire-Ø 1.4-1.6; for 8.00 m		122.0065
	130	PTFE core liner 2.0/4.0; red; Wire-Ø 0.8-1.2; for 8.00 m		126.0030
		PTFE core liner 2.7/4.7; yellow; Wire-Ø 1.4-1.6; for 8.00 m		126.0047
		PTFE carbon core liner 2.0/4.0; Wire-Ø 0.8-1.2; for 8.00 m		127.0009
		PTFE carbon core liner 2.7/4.7; Wire-Ø 1.4-1.6; for 8.00 m		127.0014
		Polyamid core liner 2.0/4.0; Wire-Ø 0.8-1.2; for 8.00 m		128.0019
		Polyamid core liner 2.3/4.7; Wire-Ø 1.4-1.6; for 8.00 m		128.0023
	131	Nipple for core liner at 4.0	20 pcs.	131.0001
		Nipple for core liner at 4.7	20 pcs.	131.0002
	132	O-ring 3.5x1.5	20 pcs.	165.0008
	133	Guide tube for core liners up to 4.0 (200 mm)		129.0461
200	Spanner		191.0001	



Alexander Binzel Schweisstechnik GmbH & Co. KG
P. O. Box 10 01 53 · D-35331 Giessen
Phone: ++49 (0) 64 08 / 59-0
Fax: ++49 (0) 64 08 / 59-191

www.binzel-abicor.com